

TOX®-Spray System SP

Data sheet 80.02
2018/12

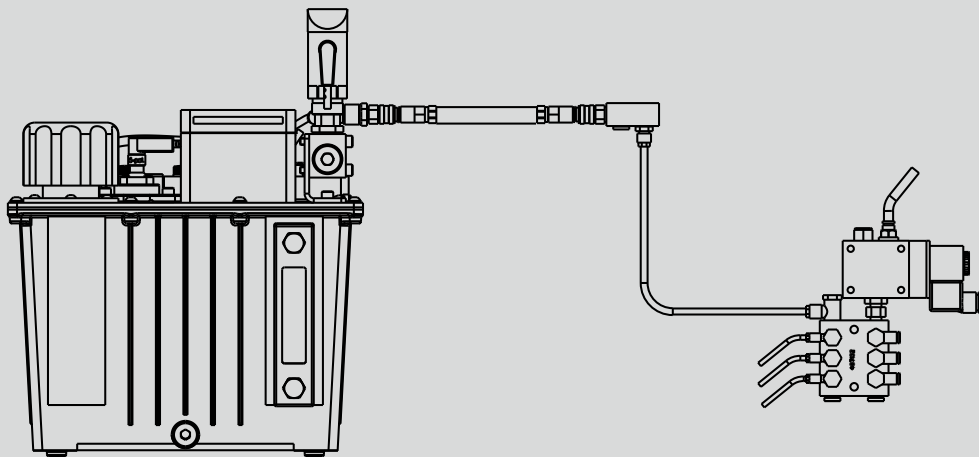

TOX[®]-Spray System

Spray system type SP

The TOX[®]-Spray Systems are used to accurately apply smallest amounts of spray media onto the areas to be machined. This reduces the joining and stripping forces for example during joining. Furthermore, the degree of forming of the materials increases due to the changed friction conditions. The workpiece surfaces and / or tools are sprayed before the joining process.

The modular design of the TOX[®]-Spray System enables flexible use, independent of the application. The system can subsequently be extended in complex plants.

Spray media

Spray media with a maximum viscosity of 40 mm²/s can be applied with the spray system. The spray medium that is best suited to the technical requirements is assigned in the TOX[®]-Laboratory and is stated in the TOX[®]-Test Report. It is also possible to use spray media that are preferred by the customer. The technological usability as well as compatibility with the TOX[®]-Spray System must be tested and approved separately in this case.

Design and function

Spray head

- Dosage of the quantity discharged
- Bundling of the spray jet
- Application of the medium

Valve unit with piping system

Distribution of the medium

Container

- Storage of the medium
- Pressure build-up (process pressure/spray pressure)

The main components are configured and supplied as closed complete system.

Pump containers or pressure vessels supply the spray heads with medium via a piping system and distributor.

The spray valves which can be individually controlled apply the medium in the desired position.

Medium		Ethanol water 50%	Induoil HL 2	Induoil HL 4	Induoil HL 20	Induoil HL 40
Viscosity at 40° C	mm ² /s	1.1	1.4	2.5s	20	35
Spray head		SPE	SPE	SPE	SPE	SPK
min. quantity per impulse	[ml]	0.01	0.01	0.011	0.012	0.013
Standard nozzle	[mm]	0.25	0.25	0.25	0.25	0.2
Pipeline pressure/container pressure	[bar]	2 - 2.5	2 - 2.5	2 - 2.5	2 - 2.5	2 - 2.5
Normal use		Aluminium	Aluminium	Steel	Steel	Stainless steel
Comment		volatilised	volatilised	with residues	with residues	with residues

Note: When using non-volatile spray media, spray media residue might remain on the component.

Combination option of main components

Viscosity	Spray head	Pump container	Pressure vessel	Valve unit SPV 02
1 – 20 mm ² /s	SPE	■	■	not required
1 – 40 mm ² /s	SPK	■	■	■
> 40 mm ² /s	on request	–	–	–

Main components

Spray head SPE

- Main body with integrated valve
- Spray distance up to approx. 300 mm
- Electrically controlled
- Incl. 1000 mm connection cable with plug M 12 x 1
- Incl. 1000 mm medium hose
- Incl. joint holder SPG
- Incl. filter SPF

Version	Cable outlet		Quick coupling and screw connection
	0°	90°	
00	■	–	■
01	■	–	–
03	–	■	■
04	–	■	–

Technical data spray valve:

Voltage: 24 VDC
 Power: 5 W
 Connection: Plug M 12, 5-pole
 + 24 V PIN 4
 0 V PIN 3

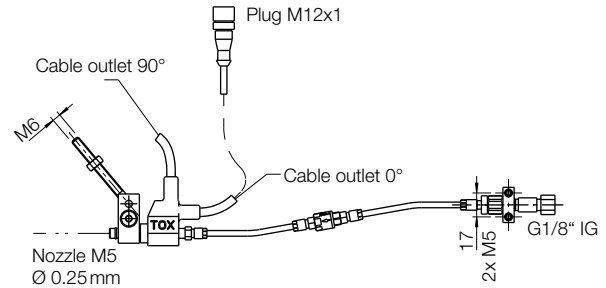

Sample order

SPE 02.00
 └── Version
 └── Electr. spray head
 └── Spray head type

Spray head SPK

- Coaxial spray head
- Spray distance up to approx. 300 mm
- Pneumatically controlled
- For spray media with viscosity up to 40 mm²/s
- Connections: M-Medium, S-Control air
- Incl. joint holder SPG
- Incl. filter SPF

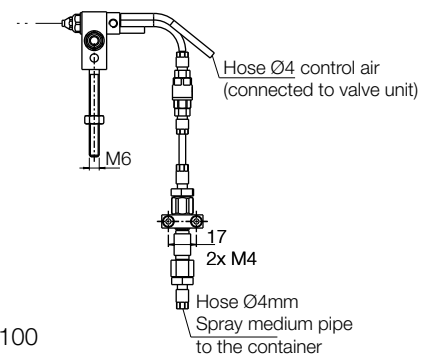

Order number
 SPK 01.01.050.100

Joint holder SPG

- Spray head clamp
- Connection thread M 6

Flexible holder for spray heads SPE and SPK. Enables accurate setting of the spray direction.

Integrated into spray head, can be ordered separately.

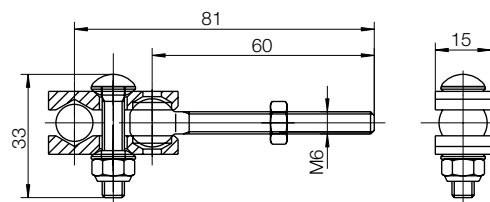

Order number
 SPG 01.00

Filter SPF

- Screw connection for hose line
- Connection Ø 4 mm
- Mesh size 0.75 µm

Integrated into spray head, can be ordered separately.

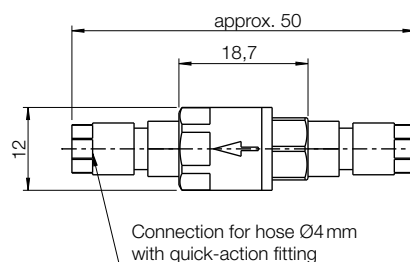

Order number
 SPF 03.075.00.000

Main components

Valve unit SPV 02

- 3/2-way valve for controlling spray head SPK
- Connection thread 1/4"

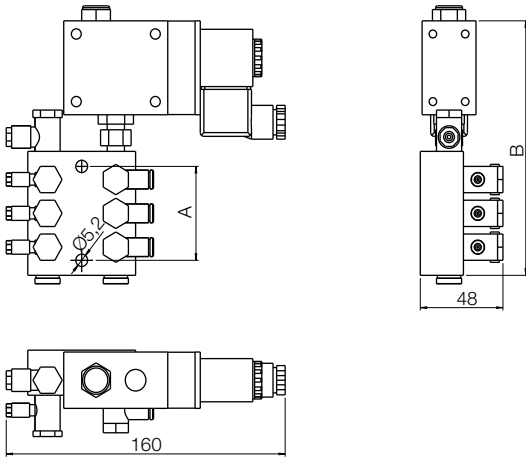

Type	SPV 02.01.01A	SPV 02.01.02A	SPV 02.01.03A
Connections	1 x Medium 1 x Control air	2 x Medium 2 x Control air	3 x Medium 3 x Control air
A	32	32	50
B	113	113	136

Distributor SPV 06 for spray media

Type SPV 06.01.00

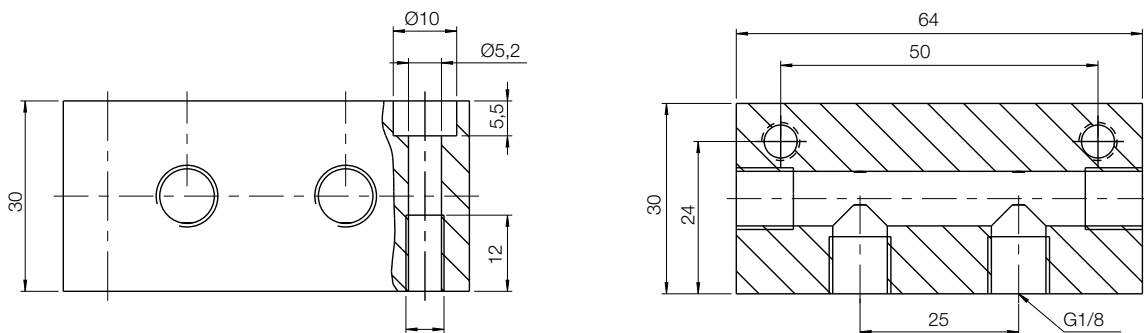

TOX®-Pressure Vessel SPB 06.02.02.20

consisting of:

- Filler container pot made of stainless steel with 6l capacity
 - Feed opening with blanking cover
 - Filling aid
 - Wall mount
- Pressure regulator for adjusting the container pressure (0 – 6 bar), air shutoff valve for application of compressed air with fast aeration, TÜV (Technical Inspection Agency) safety valve, medium feed by means of riser with check valve and filter
- Potential-free 2-point level monitoring
 - 1. switching point approx. 30 % before empty
 - 2. switching point approx. 10 % before empty
 - Connection: Plug M12x1, 5-pole

Advantages

- Increased chemical resistance
- Easy handling
- Also suitable for ethanol water
- Simple integration into complete system

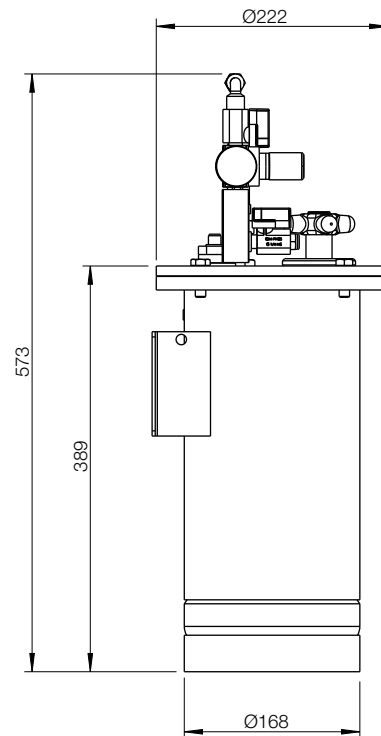

TOX®-Pump Container SPB 12.02.01.00

consisting of:

- Aluminium container with approx. 11l capacity for the use of induoil HL2, HL4, HL20, HL40 as spray medium
- Electric pump for building up system pressure
- Potential-free 2-point level monitoring
 - 1. switching point approx. 30 % before empty
 - 2. switching point approx. 10 % before empty

Optional:

- Connection cable for connecting TOX®-Control and spray medium container

Advantages

- Control technology for filling the container and controlling the medium pressure
- Sensors for leak detection (for example in case of hose bursts)
- Filling possible during the clinching process

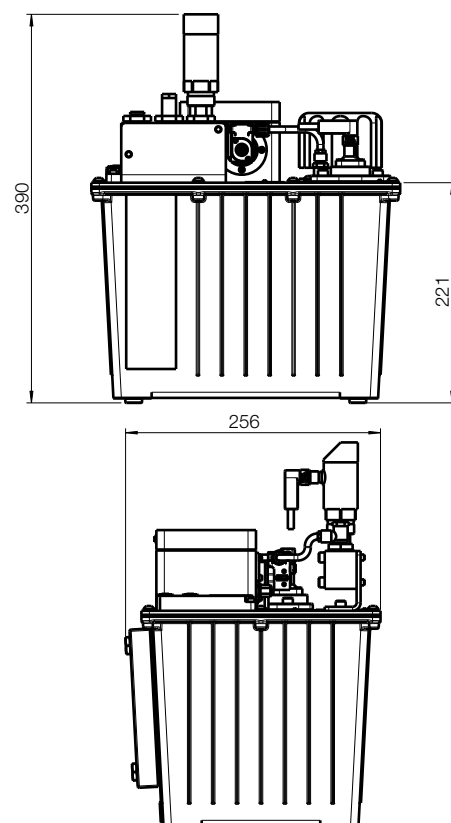

Standard versions

Spray system SP 01

Spray head SPK with TOX®-Pressure Vessel

for viscosity up to 40 mm²/s

- Spray head SPK
- Valve unit SPV 02, max. 3 spray nozzles per valve unit possible
- Piping system max. 10m
- TOX®-Pressure Vessel SPB 06.02.02.20

Operating principle

The pressure vessel supplies the spray nozzle with the medium via the piping system. An upstream 3/2-way valve controls the opening time of the spray nozzles or the quantity discharged respectively.

Spray distance up to 300mm.

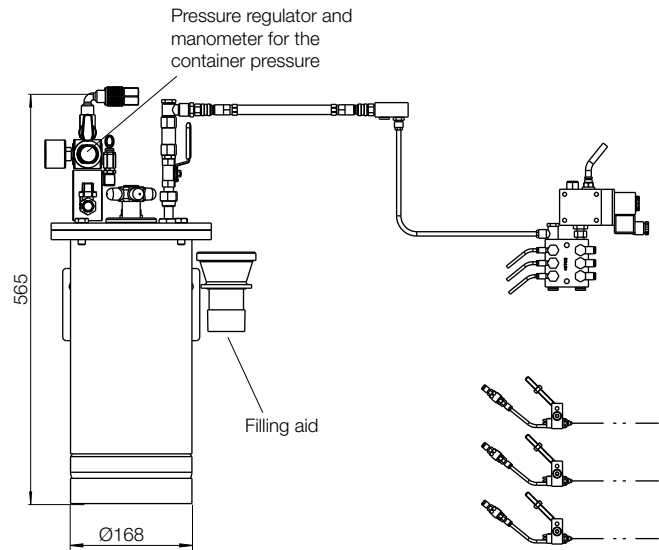

Spray system SP 02

Spray head SPE with TOX®-Pressure Vessel

for viscosity up to max. 20 mm²/s

Spray head SPE

- Distributor SPV 06, max. 5 spray nozzles per distributor possible
- Piping system max. 10m
- TOX®-Pressure Vessel SPB 06.02.02.20

Operating principle

The pressure vessel supplies the spray nozzle with the medium via the piping system. The opening time or quantity discharged is controlled by an integrated electromagnetic valve (integrated into the spray head).

Spray distance up to 300mm.

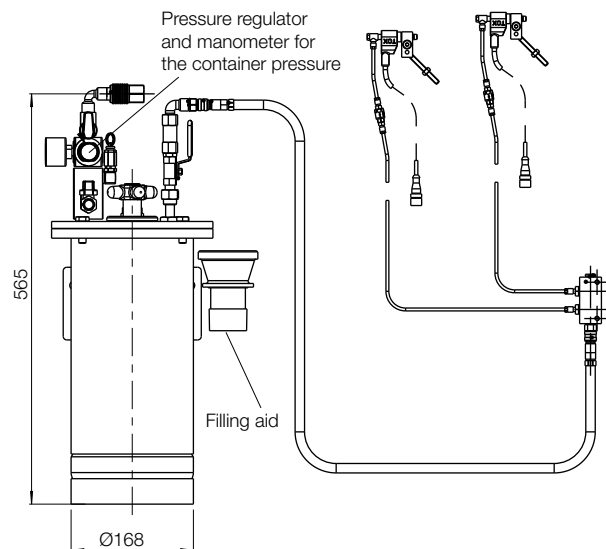

Spray system SP 04

Spray head SPE with depressurised TOX®-Pump Container

for viscosity up to max. 20 mm²/s

Spray head SPE

- Distributor SPV 06, max. 5 spray nozzles per distributor possible
- Piping system max. 10m
- TOX®-Pump Container SPB 12.02.01.00

Operating principle

The pump container supplies the spray nozzle with the medium via the piping system. The opening time or quantity discharged is controlled by an integrated electromagnetic valve (integrated into the spray head). The system pressure is generated via an electric pump.

Spray distance up to 300mm.

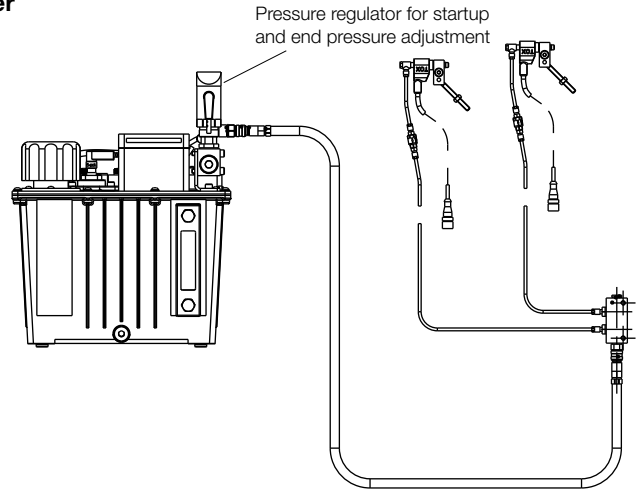

Spray system SP 05

Spray head SPK with depressurised TOX®-Pump Container

for viscosity up to 40 mm²/s

Spray head SPK

- Valve unit SPV 02, max. 3 spray nozzles per valve unit possible
- Piping system max. 10m
- TOX®-Pump Container SPB 12.02.01.00

Operating principle

The pump container supplies the spray nozzle with the medium via the piping system. An upstream 3/2-way valve controls the opening time of the spray nozzles or the quantity discharged respectively. The system pressure is generated via an electric pump.

Spray distance up to 300mm.

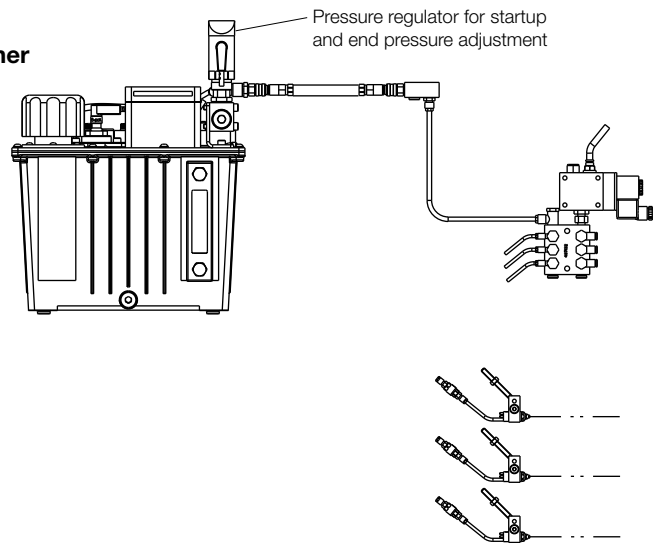

Spraying through stripping sleeves

Operating principle

A mixture of spray medium and air is premixed in a chamber in the stripper and / or tool holding fixture and then sprayed onto the workpiece through the stripper by an air pulse.

